

AUGUST®

User Manual

EPG100L

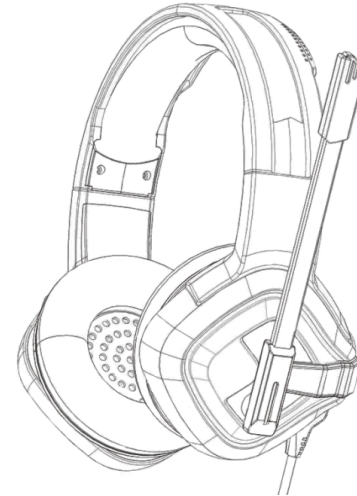

August International Ltd
Rawmec Business Park
Hoddesdon
EN11 0EE
United Kingdom
T: +44(0) 845 250 0586
(Carrier Rates Apply)
E: service@augustint.com

EU Distributor:
Daffodil Germany GmbH
Bayernstr. 10
D-30855 Langenhagen
Germany
T: +49 (0) 511 97812978

www.augustint.com

- EN Gaming Headset
- FR Casque Gaming
- DE Gaming Headset
- IT Cuffie da Gioco
- ES Auriculares Gaming
- PL Zestaw słuchawkowy dla graczy
- RU Игровая гарнитура
- CN 游戏耳机

1. Product Description

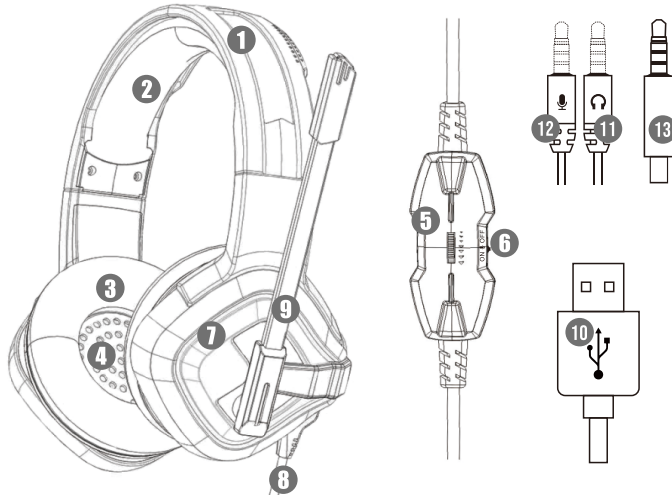

- ❶ Twisting steel head beam designed for safety
- ❷ Light and thin leather headband for comfort
- ❸ Ear pieces designed for gaming use
- ❹ 50mm speaker units for real game sound
- ❺ Volume control
- ❻ Microphone switch
- ❼ No unnecessary colourful marquee
- ❽ OFC strong copper-wire sound transmission
- ❾ 90° rotating microphone with 360° pick up
- ❿ USB cable
- ⓫ Audio cable
- ⓬ Microphone cable
- ⓭ Jack 3.5mm adaptor

2. Product Parameters

Microphone Dimensions	≈16cm
Sensitivity	42±3%db
Directivity	Omnidirectional
Microphone Imedance	2.2kΩ
Speaker Diameter	50mm
Impedance	32Ω±15%
Frequency Response	20~20000Hz
Max input Power	20WH
Voltage	3~5V
Line Length	≈2.2m
Net Weight	350g
Dimension	210x190x107mm

3. FAQs

❶ What do I do when there is no sound?

Turn up the volume on both the Headset and your Laptop, and that all cables are connected correctly.

❷ What do I do when the microphone does not work?

Please make sure all cables and connections, particularly the audio microphone jack and audio adaptor, are connected correctly. Test with other devices to see if it is a cable or device issues.

❸ What do I do when only one side of the headphones works?

Please ensure the connection is tight, as you may only hear sound through one speaker if this is not the case. Please check the audio balance. Try rotating the audio plug.

4. Warranty

This product is guaranteed for twelve months from the date of the original purchase. In the unlikely event of any defect arising due to faulty materials or workmanship, the unit will be either replaced or repaired free of charge (where possible) during this period. An alternative product will be offered in case the product is no longer available or repairable.

This warranty is subject to the following conditions:

- The warranty is only valid within the country where the product is purchased.
- The product must be correctly installed and operated in accordance to the instructions given in this user manual.
- The product must be used solely for domestic purposes.
- The warranty only covers the main unit, and does not cover the accessories.
- The warranty does not cover the damage caused by misuse, negligence, accident and natural disaster.
- The warranty will be rendered invalid if the product is resold or has been damaged by inexpert repairs. The manufactures disclaim any liability for incidental or consequential damages.
- Please consult our customer adviser before returning any product; we are not responsible for any unexpected product returns.
- Any faulty product must be kept and returned in the original packaging with all the accessories and the original copy of the purchase receipt.

The warranty is in addition to, and does not diminish, your statutory or legal rights.

Customer Service:

Telephone: +44 (0)845 250 0586
Email: service@augustint.com

This product is in compliance with the essential requirements and other relevant provisions of Directive 2014/53/EU. The Declaration of conformity may be consulted online at <http://www.augustint.com/en/declaration>



Note: This equipment has been tested and found to comply with the limits for a Class B digital device, pursuant to part 15 of the FCC Rules. These limits are designed to provide reasonable protection against harmful interference in a residential installation. This equipment generates uses and can radiate radio frequency energy and, if not installed and used in accordance with the instructions, may cause harmful interference to radio communications. However, there is no guarantee that interference will not occur in a particular installation. If this equipment does cause harmful interference to radio or television reception, which can be determined by turning the equipment off and on, the user is encouraged to try to correct the interference by one or more of the following measures:

- Reorient or relocate the receiving antenna.
- Increase the separation between the equipment and receiver.
- Connect the equipment into an outlet on a circuit different from that to which the receiver is connected.
- Consult the dealer or an experienced radio/TV technician for help.

No Unauthorized Modifications: Do not make any changes or modifications to this product without the prior express written approval of August International Ltd. Any changes or modifications made without express written approval could void the user's authority to operate this product.



For details of further relevant technical standards, please contact us at the address above.